



MCP7384X Evaluation Kit User's Guide

Note the following details of the code protection feature on Microchip devices:

- Microchip products meet the specification contained in their particular Microchip Data Sheet.
- Microchip believes that its family of products is one of the most secure families of its kind on the market today, when used in the intended manner and under normal conditions.
- There are dishonest and possibly illegal methods used to breach the code protection feature. All of these methods, to our knowledge, require using the Microchip products in a manner outside the operating specifications contained in Microchip's Data Sheets. Most likely, the person doing so is engaged in theft of intellectual property.
- Microchip is willing to work with the customer who is concerned about the integrity of their code.
- Neither Microchip nor any other semiconductor manufacturer can guarantee the security of their code. Code protection does not mean that we are guaranteeing the product as "unbreakable."

Code protection is constantly evolving. We at Microchip are committed to continuously improving the code protection features of our products. Attempts to break microchip's code protection feature may be a violation of the Digital Millennium Copyright Act. If such acts allow unauthorized access to your software or other copyrighted work, you may have a right to sue for relief under that Act.

Information contained in this publication regarding device applications and the like is intended through suggestion only and may be superseded by updates. It is your responsibility to ensure that your application meets with your specifications. No representation or warranty is given and no liability is assumed by Microchip Technology Incorporated with respect to the accuracy or use of such information, or infringement of patents or other intellectual property rights arising from such use or otherwise. Use of Microchip's products as critical components in life support systems is not authorized except with express written approval by Microchip. No licenses are conveyed, implicitly or otherwise, under any intellectual property rights.

Trademarks

The Microchip name and logo, the Microchip logo, Accuron, dsPIC, KEELOQ, MPLAB, PIC, PICmicro, PICSTART, PRO MATE and PowerSmart are registered trademarks of Microchip Technology Incorporated in the U.S.A. and other countries.

AmpLab, FilterLab, microID, MXDEV, MXLAB, PICMASTER, SEEVAL and The Embedded Control Solutions Company are registered trademarks of Microchip Technology Incorporated in the U.S.A.

Application Maestro, dsPICDEM, dsPICDEM.net, ECAN, ECONOMONITOR, FanSense, FlexROM, fuzzyLAB, In-Circuit Serial Programming, ICSP, ICEPIC, microPort, Migratable Memory, MPASM, MPLIB, MPLINK, MPSIM, PICkit, PICDEM, PICDEM.net, PowerCal, PowerInfo, PowerMate, PowerTool, rLAB, rfPIC, Select Mode, SmartSensor, SmartShunt, SmartTel and Total Endurance are trademarks of Microchip Technology Incorporated in the U.S.A. and other countries.

Serialized Quick Turn Programming (SQTP) is a service mark of Microchip Technology Incorporated in the U.S.A.

All other trademarks mentioned herein are property of their respective companies.

© 2003, Microchip Technology Incorporated, Printed in the U.S.A., All Rights Reserved.

 Printed on recycled paper.

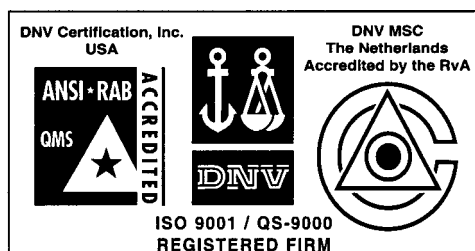

Microchip received QS-9000 quality system certification for its worldwide headquarters, design and wafer fabrication facilities in Chandler and Tempe, Arizona in July 1999 and Mountain View, California in March 2002. The Company's quality system processes and procedures are QS-9000 compliant for its PICmicro® 8-bit MCUs, KEELOQ® code hopping devices, Serial EEPROMs, microperipherals, non-volatile memory and analog products. In addition, Microchip's quality system for the design and manufacture of development systems is ISO 9001 certified.



MCP7384X EVAL KIT USER'S GUIDE

Table of Contents

Preface	v
Chapter 1. Product Overview	
1.1 What is the MCP7384X Evaluation Board	1
1.2 MCP7384X Evaluation Board Kit Components	1
Chapter 2. MCP7384X Evaluation Board Installation	
2.1 Features	3
2.2 Getting Started	3
2.3 Detailed Description	4
Appendix A. Schematic and Layouts	
A.1 Introduction	7
A.2 Highlights	7
A.3 Board Schematic	8
A.4 Board - Top Assembly	9
A.5 Board - Top Layer	10
A.6 Board - Bottom Layer	11
Appendix B. Bill-of-Materials (BOM)	
Worldwide Sales and Service	14

MCP7384X Eval Kit User's Guide

NOTES:

Preface

INTRODUCTION

This section contains general information that will be useful to know before using the MCP7384X Evaluation Board. This board currently supports the following devices:

- MCP73841, MCP73842, MCP73843, MCP73844

HIGHLIGHTS

This section covers the following topics:

- About this Guide
- Recommended Reading
- The Microchip Internet Web Site
- Customer Support

ABOUT THIS GUIDE

Document Layout

The User's Guide layout is as follows:

- **Chapter 1: Product Overview** – Important information about the MCP7384X Evaluation Board.
- **Chapter 2: MCP7384X Evaluation Board Installation** – For users evaluating the MCP73841, MCP73842, MCP73843 or MCP73844 devices, this chapter describes how to use the various features of the hardware.

Appendices:

- **Appendix A: Schematic and Layouts** – shows the schematic and layout diagrams for the MCP7384X Evaluation Board.
- **Appendix B: Bill of Materials** – lists the parts used to build the MCP7384X Evaluation Board.
- **Worldwide Sales and Service** – gives the address, telephone and fax number for Microchip Technology Inc. sales and service locations throughout the world.

MCP7384X Eval Kit User's Guide

RECOMMENDED READING

For more information regarding the MCP7384X devices, the following is recommended reading.

MCP7384X Data Sheet (DS21823)

This document provides detailed information regarding the MCP7384X Advanced Single or Dual Cell Lithium-Ion/Lithium-Polymer Charge Management Controllers.

Technical Library CD-ROM (DS00161)

This CD-ROM contains comprehensive application notes, data sheets and technical briefs for all Microchip products. To obtain this CD-ROM, contact the nearest Microchip Sales and Service location (see back page).

THE MICROCHIP INTERNET WEB SITE

Microchip provides easy access to our documentation and on-line support through our World Wide Web Site at www.microchip.com. You can download files from the web site or from our FTP site at <ftp://ftp.microchip.com>.

CUSTOMER SUPPORT

Users of Microchip products can receive assistance through several channels:

- Distributor or Representative
- Local Sales Office
- Field Application Engineer (FAE)
- Corporate Applications Engineer (CAE)
- Hot line

Customers should call their distributor, representative or field application engineer (FAE) for support. Local sales offices are also available to help customers. See the back cover for a listing of sales offices and locations.

Corporate applications engineers (CAEs) may be contacted at (480) 786-7627.

In addition, there is a Systems Information and Upgrade Line. This line provides system users a listing of the latest versions of all of Microchip's development systems software products. Plus, this line provides information on how customers can receive any currently available upgrade kits.

The Hotline numbers are:

- 1-800-755-2345 for U.S. and most of Canada, and
- 1-480-786-7302 for the rest of the world.

Chapter 1. Product Overview

1.1 WHAT IS THE MCP7384X EVALUATION BOARD

The MCP7384X Evaluation Board is an evaluation and demonstration tool for Microchip Technology's MCP7384X Advanced Single or Dual Cell Lithium-Ion/Lithium-Polymer Charge Management Controllers. The design provides for dynamic versatility while being able to handle accurate measurements.

When connected, this evaluation board allows for the evaluation of the MCP7384X devices in a variety of applications.

1.2 MCP7384X EVALUATION BOARD KIT COMPONENTS

The MCP7384X Evaluation Kit contains:

- MCP7384X Evaluation Board
- MCP73841-420I/UN, MCP73842-840I/UN and MCP73843-420I/MS Devices installed
- MCP7384X Data Sheet (DS21823)
- MCP7384X Evaluation Kit User's Guide (DS51424)

MCP7384X Eval Kit User's Guide

NOTES:

Chapter 2. MCP7384X Evaluation Board Installation

2.1 FEATURES

The MCP7384X Evaluation Board has the following features:

- Evaluation of MCP73841/42 in 10-pin MSOP packages
- Evaluation of MCP73843/44 in 8-pin MSOP packages
- Simple stand-alone operation or microcontroller compatible
- Powered from external bench supply or voltage regulated wall cube
- Surface-mount design
- Fully assembled and tested

2.2 GETTING STARTED

The MCP7384X Evaluation Board is a fully functional, assembled, and tested surface mount board for evaluation of Microchip's MCP7384X Advanced Single or Dual Cell Lithium-Ion/Lithim-Polymer Charge Management Controllers. The following steps provide simple stand-alone operation. Refer to Figure 2-1 for the set-up configuration diagram. The set-up configuration diagram depicts evaluation with circuit 1, MCP73841 operation. **Note:** Do not turn on the input power until all other set-up steps are complete.

1. Connect an external bench supply or voltage regulated wall cube to the appropriate circuit for evaluation.

CAUTION: Observe correct polarity of connection. Positive connects to VDDn; negative connects to VSSn; where n represents the circuit to be evaluated.

2. Connect a single or dual cell Li-Ion battery pack to the appropriate circuit for evaluation. Circuits 1 and 3 support single cell applications; circuit 2 supports dual cell applications based on the original devices installed.

CAUTION: Observe correct polarity of connection. Positive connects to VBATn; negative connects to VSSn; where n represents the same circuit to be evaluated as step 1.

3. For circuit 1 or circuit 2 evaluation, connect an external battery pack thermistor to the appropriate THERM input. The thermistor should be connected from THERMn to VSSn. If continuous cell temperature monitoring is not desired, utilize circuit 3 or place a 10 k Ω resistor from THERMn to VSSn.
4. Turn on bench supply or plug in wall cube.
5. A GREEN LED should illuminate to indicate the presence of input power. A RED LED provides status during the charge cycle. Refer to the MCP7384X Data Sheet (DS21823) for details.

MCP7384X Eval Kit User's Guide

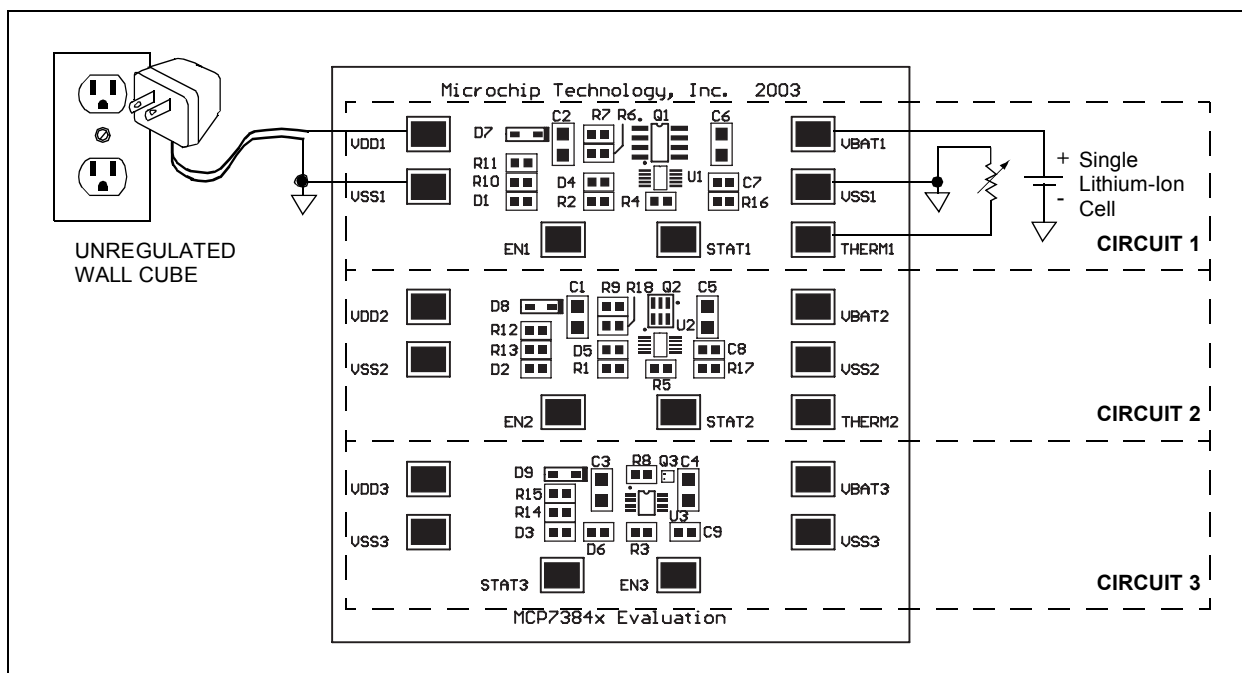

FIGURE 2-1: Set-up Configuration Diagram.

2.3 DETAILED DESCRIPTION

The MCP7384X Evaluation Board is designed to evaluate simple, stand-alone, linear charging of single or dual cell Lithium-Ion/Lithium-Polymer battery packs. Two single cell reference designs and one dual cell reference design are provided. Each reference design can be evaluated independently and utilizes a different pass transistor, each in a unique package, to demonstrate the versatility of the MCP7384X charge management controllers. The reference designs provide constant current charging followed by constant voltage charging with automatic charge termination. Three levels of constant current, one for each reference design, are demonstrated: 500 mA, 1A and 275 mA for the two single cell reference designs and the dual cell reference design, respectively. The MCP73841 is provided in a 10-pin MSOP package and is equipped with shutdown control, status indicator, safety timer, and continuous cell temperature monitor. The MCP73842 is provided in a 10-pin MSOP package and is equipped with the same features as the MCP73841. The MCP73841 and MCP73842 provide charge management for single and dual cell Lithium-Ion/Lithium-Polymer battery packs, respectively. Alternatively, the MCP73843 is provided in an 8-pin MSOP package. The MCP73843 provides charge management for single cell Lithium-Ion/Lithium-Polymer battery packs. The MCP73843 is equipped with all the features of the MCP73841 and MCP73842, with the exception of the cell temperature monitor. Refer to the MCP7384X data sheet (DS21823) for details on the individual device features.

2.3.1 Input Source

The MCP7384X Evaluation Board is designed to provide typical fast charge currents of 1 A, 275 mA and 500 mA for circuits 1, 2 and 3, respectively. A 5V \pm 10%, 7.5W input source should be utilized to power the evaluation kit when evaluating the single cell charge management devices (MCP73841 and MCP73843). A 10V \pm 10%, 5W input source should be utilized to power the evaluation kit when evaluating the dual cell charge management device (MCP73842). Independent input source connections are provided for each reference design.

Higher or lower fast charge currents can be obtained by adjusting the value of the sense resistors (R6//R7, R9//R18 and R8 for circuits 1, 2 and 3, respectively). A corresponding higher or lower power input source may need to be utilized. Care should be taken not to over-stress the pass transistors with excessive power dissipation when higher fast charge currents are desired.

2.3.2 Reverse-Blocking Protection

The MCP7384X Evaluation Board is designed to provide reverse-blocking protection in the event a reversed polarity input source is connected. The reverse-blocking protection diodes also ensure that a faulted or shorted input source will not adversely effect the battery pack.

2.3.3 Battery Headers

Independent battery connections are provided for each reference design. For the MCP73841 and MCP73842 reference designs, a connection is provided for a nominal 10 k Ω at 25°C NTC thermistor situated in the battery pack for temperature sensing. Installed resistors provide a charging window when the cell temperature is between -5°C and +55°C when a thermistor with a sensitivity index (β) of 3982 is utilized. When the cell temperature deviates outside the preset window, charging is inhibited. The desired charging window for a variety of thermistors can be obtained by changing the values of resistors R4 and R16 or R5 and R17 for circuits 1 and 2, respectively. Refer to the MCP7384X data sheet (DS21823) for details.

<p>CAUTION: Improper connection of the battery may result in damage to the battery and the possibility of personal injury. It is also important to avoid shorting the battery terminals together.</p>
--

2.3.4 Device Support Options

The MCP7384X Evaluation Board supports the entire MCP7384X family and provides three reference designs utilizing the MCP73841, MCP73842, and MCP73843. Alternate devices can be substituted in order to evaluate the different MCP7384X family options.

2.3.5 Microcontroller option

Connection points provide easily accessible locations for interface to a host microcontroller. The host microcontroller can be used to disable the charger, monitor charge status or terminate a charge.

2.3.6 Output voltage options

The MCP7384X Evaluation Board is provided with a constant voltage mode output voltage of 4.2V and 8.4V for single or dual cell Lithium-Ion/Lithium-Polymer battery packs, respectively. Evaluation with a constant voltage mode output voltage of 4.1V or 8.2V can be achieved by replacing U1, U2 or U3 with the appropriate device. Refer to the MCP7384X data sheet (DS21823) for device ordering information.

MCP7384X Eval Kit User's Guide

NOTES:

Appendix A. Schematic and Layouts

A.1 INTRODUCTION

This appendix contains the schematics and layouts for the MCP7384X Evaluation Board.

A.2 HIGHLIGHTS

Diagrams included in this appendix:

- Board Schematic
- Board - Top Assembly
- Board - Top Layer
- Board - Bottom Layer

MCP7384X Eval Kit User's Guide

A.3 BOARD SCHEMATIC

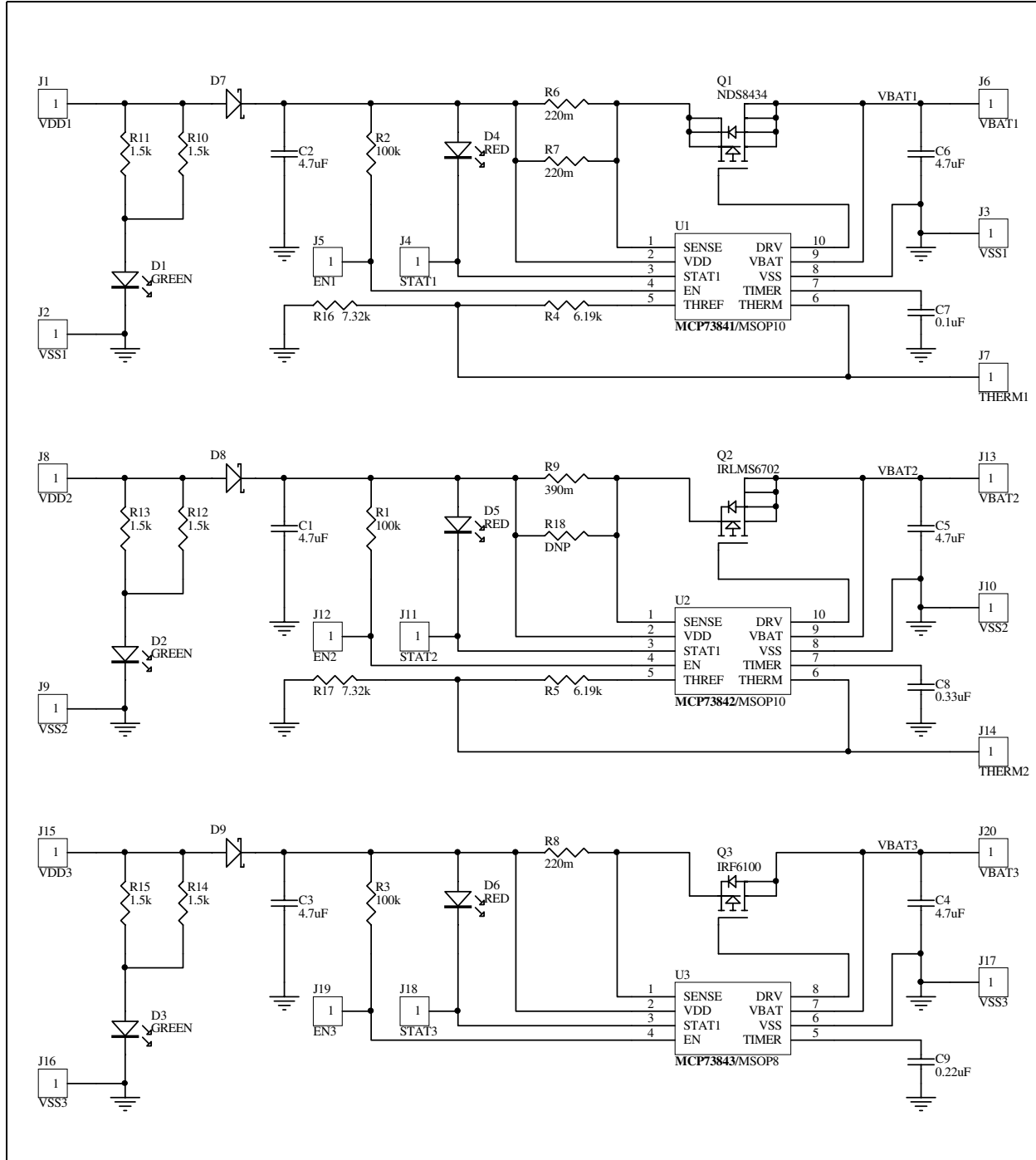

A.4 BOARD - TOP ASSEMBLY

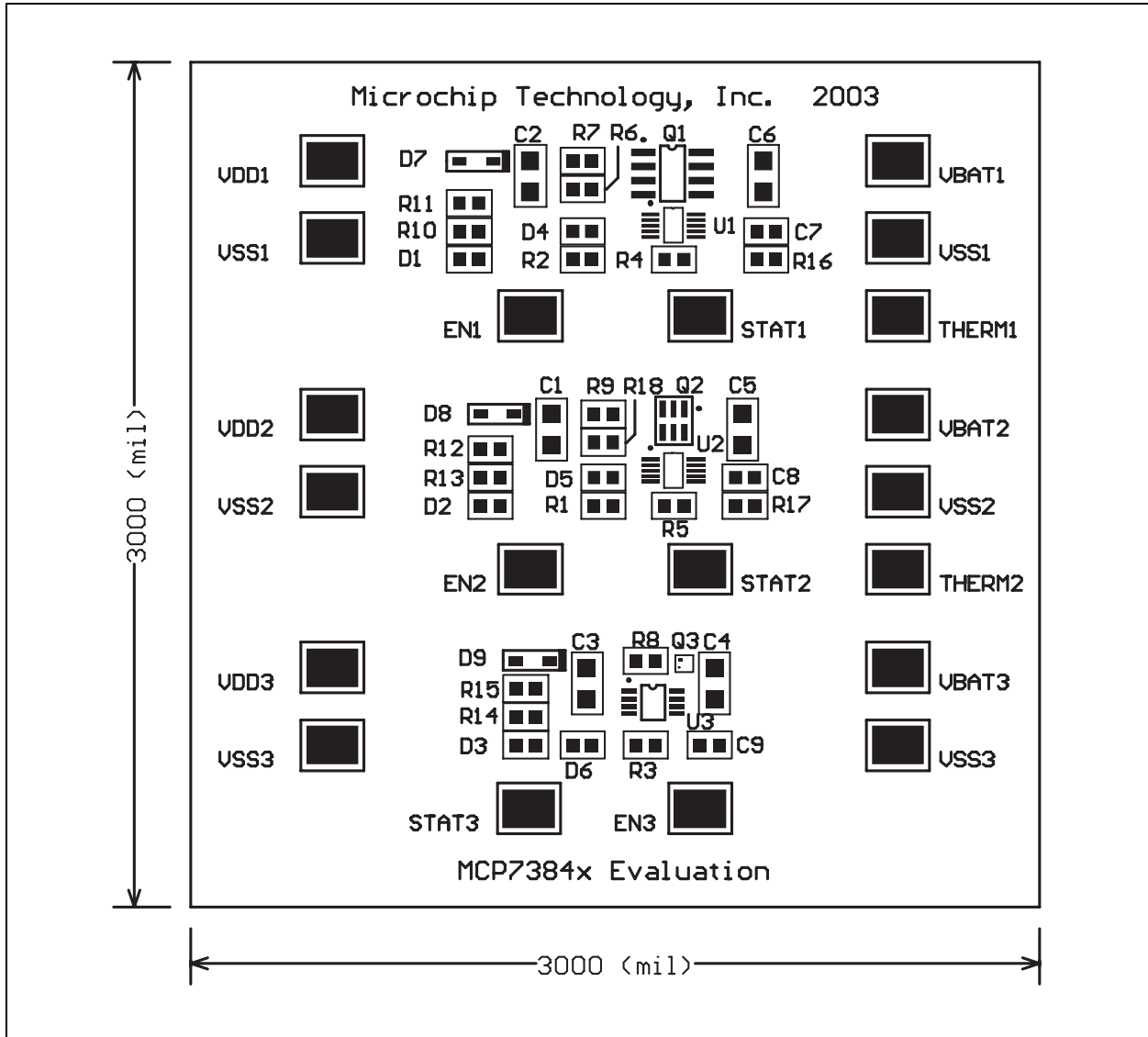

MCP7384X Eval Kit User's Guide

A.5 BOARD - TOP LAYER

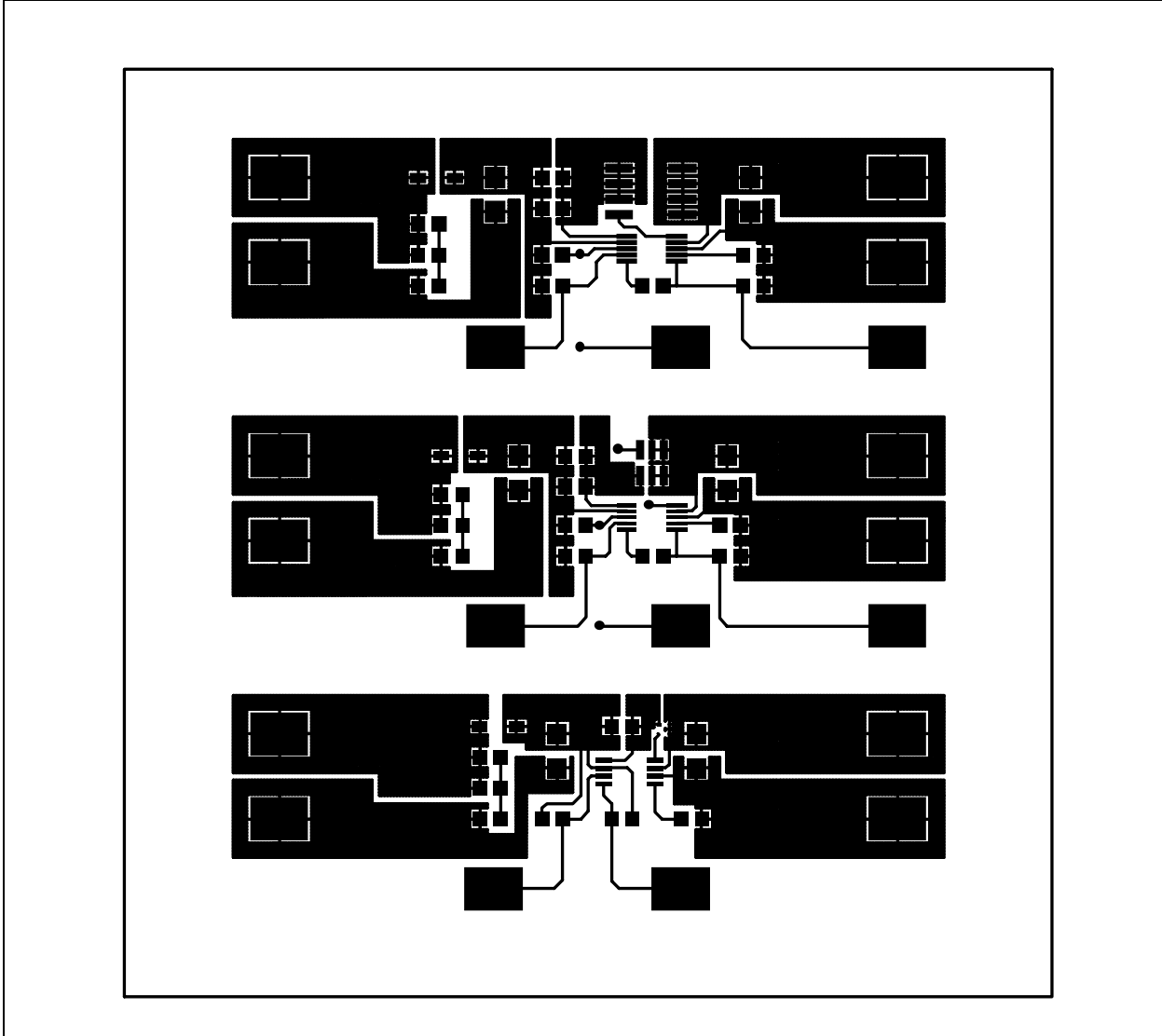

A.6 BOARD - BOTTOM LAYER

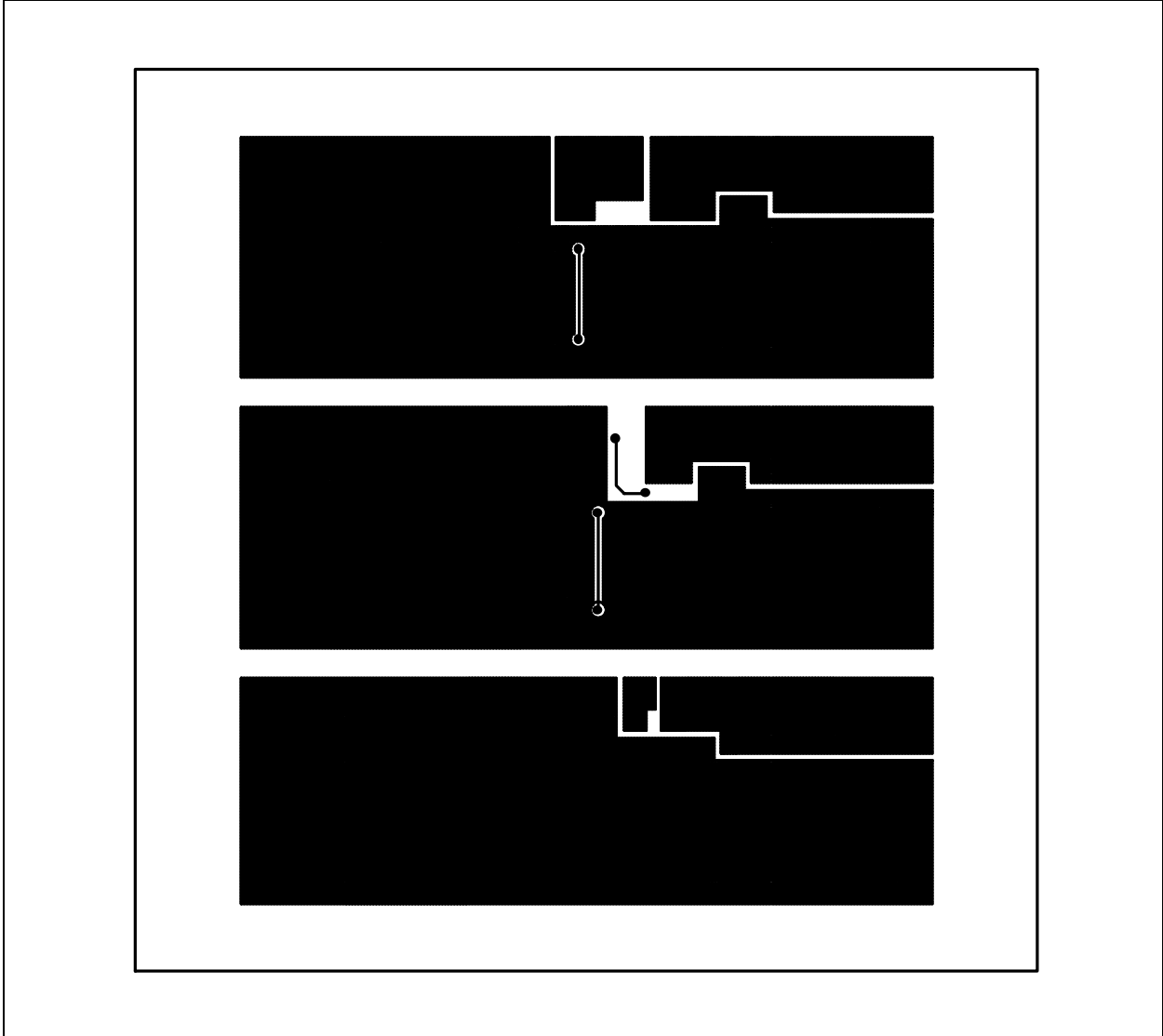

MCP7384X Eval Kit User's Guide

NOTES:

Appendix B. Bill-of-Materials (BOM)

TABLE B-1: BILL OF MATERIALS

Reference Designator	Quantity	Description	Manufacturer	Manufacturer Part Number
C1 - C6	6	4.7 μ F, X5R Ceramic, 16V, 1206	Panasonic™	ECJ-3YB1C475K
C7	1	0.1 μ F, X7R Ceramic, 16V, 0603	Panasonic	ECJ-1VB1C104K
C8	1	0.33 μ F, X5R Ceramic, 16V, 0603	Panasonic	ECJ-1VB1A334K
C9	1	0.22 μ F, X5R Ceramic, 16V, 0603	Panasonic	ECJ-1VB1A224K
D1 - D3	3	Green LED, 0603	Lumex™	SML-LX0603GW
D4 - D6	3	Red LED, 0603	Lumex	SML-LX0603SRW
D7 - D9	3	Schottky Diode, 1A, 25V, SOD-323	Panasonic	MA2YD23
J1 - J20	20	Surface Mount Test Point, 5016	Keystone	5016
Q1	1	P-Channel Power MOSFET, SOIC8	Fairchild	NDS8434
Q2	1	P-Channel Power MOSFET, TSOP6	IR	IRLMS6702
Q2	1	P-Channel Power MOSFET, FlipFET	IR	IRF6100
R1 - R3	3	100 k Ω , 1/16W, Chip Resistor, 0603	Panasonic	ERJ-3EKF1003V
R4 - R5	2	6.19 k Ω , 1/16W, Chip Resistor, 0603	Panasonic	ERJ-3EKF6192V
R6 - R8	3	0.22 Ω , 1/10W, Chip Resistor, 0603	Panasonic	ERJ-3RQFR22V
R9	3	0.39 Ω , 1/10W, Chip Resistor, 0603	Panasonic	ERJ-3RQFR39V
R10 - R15	6	1.5 k Ω , 1/10W, Chip Resistor, 0603	Panasonic	ERJ-3GEYJ152V
R16 - R17	2	7.32 k Ω , 1/16W, Chip Resistor, 0603	Panasonic	ERJ-3EKF7322V
R18 (Note)	0	DNP		
U1	1	Single Cell Lithium-Ion Charger, MSOP10	Microchip Technology Inc.	MCP73841-420I/UN
U2	1	Dual Cell Lithium-Ion Charger, MSOP10	Microchip Technology Inc.	MCP73842-840I/UN
U3	1	Single Cell Lithium-Ion Charger, MSOP8	Microchip Technology Inc.	MCP73843-420I/MS

Note: R18 is not installed in the original factory installation. Pads are provided for a surface-mount chip resistor in a 0603 package. R18 can be installed in parallel with R9 to adjust the charge current of circuit 2. Refer to the schematic and the MCP7384X data sheet (DS21823) for more information on choosing the value of the sense resistor.



WORLDWIDE SALES AND SERVICE

AMERICAS

Corporate Office

2355 West Chandler Blvd.
Chandler, AZ 85224-6199
Tel: 480-792-7200
Fax: 480-792-7277
Technical Support: 480-792-7627
Web Address: <http://www.microchip.com>

Atlanta

3780 Mansell Road, Suite 130
Alpharetta, GA 30022
Tel: 770-640-0034
Fax: 770-640-0307

Boston

2 Lan Drive, Suite 120
Westford, MA 01886
Tel: 978-692-3848
Fax: 978-692-3821

Chicago

333 Pierce Road, Suite 180
Itasca, IL 60143
Tel: 630-285-0071
Fax: 630-285-0075

Dallas

4570 Westgrove Drive, Suite 160
Addison, TX 75001
Tel: 972-818-7423
Fax: 972-818-2924

Detroit

Tri-Atria Office Building
32255 Northwestern Highway, Suite 190
Farmington Hills, MI 48334
Tel: 248-538-2250
Fax: 248-538-2260

Kokomo

2767 S. Albright Road
Kokomo, IN 46902
Tel: 765-864-8360
Fax: 765-864-8387

Los Angeles

18201 Von Karman, Suite 1090
Irvine, CA 92612
Tel: 949-263-1888
Fax: 949-263-1338

Phoenix

2355 West Chandler Blvd.
Chandler, AZ 85224-6199
Tel: 480-792-7966
Fax: 480-792-4338

San Jose

2107 North First Street, Suite 590
San Jose, CA 95131
Tel: 408-436-7950
Fax: 408-436-7955

Toronto

6285 Northam Drive, Suite 108
Mississauga, Ontario L4V 1X5, Canada
Tel: 905-673-0699
Fax: 905-673-6509

ASIA/PACIFIC

Australia

Suite 22, 41 Rawson Street
Epping 2121, NSW
Australia
Tel: 61-2-9868-6733
Fax: 61-2-9868-6755

China - Beijing

Unit 915
Bei Hai Wan Tai Bldg.
No. 6 Chaoyangmen Beidajie
Beijing, 100027, No. China
Tel: 86-10-85282100
Fax: 86-10-85282104

China - Chengdu

Rm. 2401-2402, 24th Floor,
Ming Xing Financial Tower
No. 88 TIDU Street
Chengdu 610016, China
Tel: 86-28-86766200
Fax: 86-28-86766599

China - Fuzhou

Unit 28F, World Trade Plaza
No. 71 Wusi Road
Fuzhou 350001, China
Tel: 86-591-7503506
Fax: 86-591-7503521

China - Hong Kong SAR

Unit 901-6, Tower 2, Metroplaza
223 Hing Fong Road
Kwai Fong, N.T., Hong Kong
Tel: 852-2401-1200
Fax: 852-2401-3431

China - Shanghai

Room 701, Bldg. B
Far East International Plaza
No. 317 Xian Xia Road
Shanghai, 200051
Tel: 86-21-6275-5700
Fax: 86-21-6275-5060

China - Shenzhen

Rm. 1812, 18/F, Building A, United Plaza
No. 5022 Binhe Road, Futian District
Shenzhen 518033, China
Tel: 86-755-82901380
Fax: 86-755-8295-1393

China - Shunde

Room 401, Hongjian Building
No. 2 Fengxiangnan Road, Ronggui Town
Shunde City, Guangdong 528303, China
Tel: 86-765-8395507 Fax: 86-765-8395571

China - Qingdao

Rm. B505A, Fullhope Plaza,
No. 12 Hong Kong Central Rd.
Qingdao 266071, China
Tel: 86-532-5027355 Fax: 86-532-5027205

India

Divyasree Chambers
1 Floor, Wing A (A3/A4)
No. 11, O'Shaughnessy Road
Bangalore, 560 025, India
Tel: 91-80-2290061 Fax: 91-80-2290062

Japan

Benex S-1 6F
3-18-20, Shinyokohama
Kohoku-Ku, Yokohama-shi
Kanagawa, 222-0033, Japan
Tel: 81-45-471-6166 Fax: 81-45-471-6122

Korea

168-1, Youngbo Bldg. 3 Floor
Samsung-Dong, Kangnam-Ku
Seoul, Korea 135-882
Tel: 82-2-554-7200 Fax: 82-2-558-5932 or
82-2-558-5934

Singapore

200 Middle Road
#07-02 Prime Centre
Singapore, 188980
Tel: 65-6334-8870 Fax: 65-6334-8850

Taiwan

Kaohsiung Branch
30F - 1 No. 8
Min Chuan 2nd Road
Kaohsiung 806, Taiwan
Tel: 886-7-536-4818
Fax: 886-7-536-4803

Taiwan

Taiwan Branch
11F-3, No. 207
Tung Hua North Road
Taipei, 105, Taiwan
Tel: 886-2-2717-7175 Fax: 886-2-2545-0139

EUROPE

Austria

Durisolstrasse 2
A-4600 Wels
Austria
Tel: 43-7242-2244-399
Fax: 43-7242-2244-393

Denmark

Regus Business Centre
Lautrup høj 1-3
Ballerup DK-2750 Denmark
Tel: 45-4420-9895 Fax: 45-4420-9910

France

Parc d'Activite du Moulin de Massy
43 Rue du Saule Trapu
Batiment A - ler Etage
91300 Massy, France
Tel: 33-1-69-53-63-20
Fax: 33-1-69-30-90-79

Germany

Steinheilstrasse 10
D-85737 Ismaning, Germany
Tel: 49-89-627-144-0
Fax: 49-89-627-144-44

Italy

Via Quasimodo, 12
20025 Legnano (MI)
Milan, Italy
Tel: 39-0331-742611
Fax: 39-0331-466781

Netherlands

P. A. De Biesbosch 14
NL-5152 SC Drunen, Netherlands
Tel: 31-416-690399
Fax: 31-416-690340

United Kingdom

505 Eskdale Road
Winnersh Triangle
Wokingham
Berkshire, England RG41 5TU
Tel: 44-118-921-5869
Fax: 44-118-921-5820

07/28/03